

MAGNET CATALOGUE



- PRODUCT RANGE
- APPLICATION
- MAGNETIC SYSTEM
- INTERGRATED MANAGEMENT SYSTEM
- SAFETY GUIDELINES



MAGRON

Specialized magnetic material

● **Block**

Different Sizes
Different Coatings

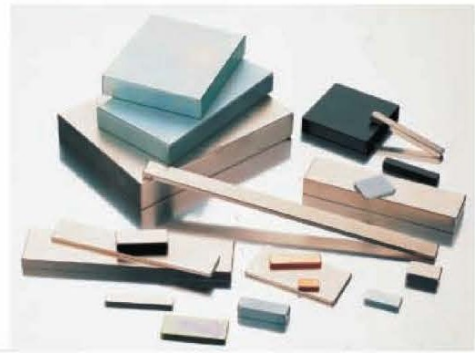

● **Segment:**

Different Sizes
Different Coatings

● **Ring:**

Different Sizes
Different Coatings



● **Cylinder:**

Different Sizes
Different Coatings

● **Others:**

Different Sizes
Different Coatings



TECHNICAL PRINCIPLES AND TERMS

Technical Terms



With more than 10 years' experience in researching and developing the fields of neodymium magnets and their applications, **MAGRON Magnet** has our strict quality management system. For instance, unless we have a special agreement with our customer, our quality inspection allows mechanical surface damages up to a total of max. 2% per pole surface.

The final inspection of our magnets and magnetic assemblies is normally based on a standardized fixed sampling rate. Unless otherwise agreed with customers, we test AQL 0.8 with the c=0 acceptance criteria. By consistently employing the latest quality assurance techniques, we are frequently able to commit even higher quality request. For example, we could offer $1.33 \leq Cpk \leq 1.67$ for some critical dimensional characteristics.

About technical research, for example, our N45 NdFeB magnet passed Hast low weightlessness and corrosion testing, which can keep losing weight less than 0.5 milligrams in the period of 10x24 hours.

We research, design and develop various NdFeB magnets and their applications by our advanced machines and high technics according to customers' request and help choose the most economical and best solutions.

Block	Length	Width	Thickness
Maximum	250.00mm	180.00mm	50.00mm
Minimum	2.60mm	1.80mm	0.50mm

Ring	Outer Diameter	Inner Diameter	Thickness
Maximum	220.00mm	80.00mm	50.00mm
Minimum	2.00mm	1.50mm	0.50mm

Disc / Cylinder	Outer Diameter	Thickness
Maximum	220.00mm	50.00mm
Minimum	1.00mm	0.50mm

● Magnetic Characteristics and Physical Properties of Sintered NdFeB Magnet

PROPERTIES GRADE	Remanence	Coercive Force	Intrinsic Coercive Force	Max Energy Product	Max Working Temp
	Br mT (Kgs)	Hcb KA/m (Koe)	Hcj KA/m (Koe)	(BH)max KJ/m ³ (MGOe)	TW °C
N33	1130-1170(11.3-11.7)	≥836(≥10.5)	≥955(≥12)	247-263(31-33)	80
N35	1170-1210(11.7-12.1)	≥868(≥10.9)	≥955(≥12)	263-287(33-36)	80
N38	1210-1250(12.1-12.5)	≥899(≥11.3)	≥955(≥12)	287-310(36-39)	80
N40	1250-1280(12.5-12.8)	≥923(≥11.6)	≥955(≥12)	302-326(38-41)	80
N42	1280-1320(12.8-13.2)	≥923(≥11.6)	≥955(≥12)	318-342(40-43)	80
N45	1320-1380(13.2-13.8)	≥876(≥11.0)	≥955(≥12)	342-366(43-46)	80
N48	1380-1420(13.8-14.2)	≥835(≥10.5)	≥876(≥11)	366-390(46-49)	80
N50	1400-1450(14.0-14.5)	≥796(≥10.0)	≥876(≥11)	382-406(48-51)	60
N52	1430-1480(14.3-14.8)	≥796(≥10.0)	≥876(≥11)	398-422(50-53)	60
N35M	1170-1220(11.7-12.2)	≥868(≥10.9)	≥1114(≥14)	263-287(33-36)	100
N38M	1220-1250(12.2-12.5)	≥899(≥11.3)	≥1114(≥14)	287-310(36-39)	100
N40M	1250-1280(12.5-12.8)	≥923(≥11.6)	≥1114(≥14)	302-326(38-41)	100
N42M	1280-1320(12.8-13.2)	≥955(≥12.0)	≥1114(≥14)	318-342(40-43)	100
N45M	1320-1380(13.2-13.8)	≥995(≥12.5)	≥1114(≥14)	342-366(43-46)	100
N48M	1360-1430(13.6-14.3)	≥1027(≥12.9)	≥1114(≥14)	366-390(46-49)	100
N50M	1400-1450(14.0-14.5)	≥1033(≥13.0)	≥1114(≥14)	382-406(48-51)	100
33H	1130-1170(11.3-11.7)	≥836(≥10.5)	≥1353(≥17)	247-271(31-34)	120
35H	1170-1210(11.7-12.1)	≥868(≥10.9)	≥1353(≥17)	263-287(33-36)	120
38H	1210-1250(12.1-12.5)	≥899(≥11.3)	≥1353(≥17)	287-310(36-39)	120
40H	1240-1280(12.4-12.8)	≥923(≥11.6)	≥1353(≥17)	302-326(38-41)	120
42H	1280-1320(12.8-13.2)	≥955(≥12.0)	≥1353(≥17)	318-342(40-43)	120
45H	1300-1360(13.0-13.6)	≥963(≥12.1)	≥1353(≥17)	342-358(43-46)	120
48H	1370-1430(13.7-14.3)	≥995(≥12.5)	≥1353(≥17)	358-390(46-49)	120
33SH	1130-1170(11.3-11.7)	≥844(≥10.6)	≥1592(≥20)	247-272(31-34)	150
35SH	1170-1210(11.7-12.1)	≥876(≥11.0)	≥1592(≥20)	263-287(33-36)	150
38SH	1210-1250(12.1-12.5)	≥907(≥11.4)	≥1592(≥20)	287-310(36-39)	150
40SH	1240-1280(12.4-12.8)	≥939(≥11.8)	≥1592(≥20)	302-326(38-41)	150
42SH	1280-1320(12.8-13.2)	≥987(≥12.4)	≥1592(≥20)	318-342(40-43)	150
45SH	1320-1380(13.2-13.8)	≥1003(≥12.6)	≥1592(≥20)	342-366(43-46)	150
28UH	1020-1080(10.2-10.8)	≥764(≥9.6)	≥1990(≥25)	207-231(26-29)	180
30UH	1080-1130(10.8-11.3)	≥812(≥10.2)	≥1990(≥25)	223-247(28-31)	180
33UH	1130-1170(11.3-11.7)	≥852(≥10.7)	≥1990(≥25)	247-271(31-34)	180
35UH	1180-1220(11.8-12.2)	≥860(≥10.8)	≥1990(≥25)	263-287(33-36)	180
38UH	1220-1250(12.2-12.5)	≥876(≥11.0)	≥1990(≥25)	287-310(36-39)	180
40UH	1240-1280(12.4-12.8)	≥899(≥11.3)	≥1990(≥25)	302-326(38-41)	180
28EH	1040-1090(10.4-10.9)	≥780(≥9.8)	≥2388(≥30)	207-231(26-29)	200
30EH	1080-1130(10.8-11.3)	≥812(≥10.2)	≥2388(≥30)	223-247(28-31)	200
33EH	1130-1170(11.3-11.7)	≥836(≥10.5)	≥2388(≥30)	247-271(31-34)	200
35EH	1170-1220(11.7-12.2)	≥876(≥11.0)	≥2388(≥30)	263-287(33-36)	200
38EH	1220-1250(12.2-12.5)	≥899(≥11.3)	≥2388(≥30)	287-310(36-39)	200

REMARKS:

- ※ The above-mentioned data of magnetic parameters and physical properties are given at room temperature.
- ※ The maximum service temperature of magnet is changeable due to the ratio length and diameter and environmental factors.
- ※ Density: 7.4~7.6g/cm³; α Br: -0.09~-0.13%/°C; α Hcj: -0.50~-0.80%/°C; Hardness: Hv 600.

NdFeB Weight Loss Rate

Testing the NdFeB weight loss rate(Trial Sample 10x10x10mm or D10x10mm), under 120°C temperature, 100% RH humidity.

Grade Series	Grade	Weight Loss Rate(mg/cm ²)			
		Test Time			
		48 Hours	96 Hours	168 Hours	240Hours
Common Grade	N45	≤ 5	≤ 15		
	N48	≤ 5	≤ 15		
Weight Loss	N50	≤ 3	≤ 10		
	42M	≤ 3	≤ 10		
	48HT	≤ 3	≤ 10		
Ultra Weight Loss	35SH	≤ 2	≤ 5	≤ 10	≤ 20
	40UH	≤ 2	≤ 5	≤ 10	≤ 20
	35EH	≤ 2	≤ 5	≤ 10	≤ 20

NdFeB Dimension and Accepted Tolerance

Dimension(mm)		Accepted Tolerance(mm)	
		Perpendicular Compression Direction	Compression Direction
≤ 10	Sintered Surface	± 0.25	± 0.3
> 10-20		± 0.40	± 0.45
> 20-50		± 0.70	± 0.85
> 50-80		± 1.10	± 1.30

Dimension(mm)		Accepted Tolerance(mm)			
		Top grinding	Inner and Outer Circle Grinding	Wire Cutting	Slicing
≤ 10	Machining Surface	± 0.05	± 0.05	± 0.03	± 0.05
> 10-20		± 0.05	± 0.08	± 0.05	± 0.08
> 20-50		± 0.10	± 0.13	± 0.08	± 0.15
> 50-80		± 0.15	± 0.20	± 0.13	± 0.20

Plating Layer and the Corrosion Resistance of Sintered NdFeB Magnet

Coating Category	Plating Code	Color	Mini Local Thickness (um)	Corrosion in time to start			Recommended Working Temperature	
				NSS	Humidity Thermal	Pressure Vessel (PCT)Test		
Electrodeposited coatings of Nickel(barrel plating)	Ni	Silver	10	24	300	48	<200	
Electrodeposited coatings of Nickel(rack plating)	Ni	Silver	10	8	300	48		
Electrodeposited coatings of Nickel-Cu+Nickel(barrel plating)	NiCuNi	Silver	10	72	500	48		
Electrodeposited coatings of Nickel-Cu+Nickel(rack plating)	NiCuNi	Silver	10	48	500	48		
Electrodeposited coatings of Nickel	Zinc plating-Blue White	Zn	Blue-White	4	24	48	/	<170
	Colour Zinc	CZn/Colour Zn	Colourful	6	48	48	/	
Chemical Ni plating	Ni	Silver	12	96	500	48	<200	
Epoxy electrophoresis	Epoxy	Black/Gray	10	48-96	120	0-24	<130	

※ PCT Test(120°C, 100%RH,2.0atm); Salt Spray Test(5%NaCl, 35°C continuous spray).

Coating and Corrosive Resistance of Sintered NdFeB

Surface	Coating	Colour	Thickness(μm)	Standard Resistance		Corrosive Resistance
				PCT Test	Salt Spray Test	
Nickel	Nickel	Silver	10-20	48hr or 72hr	72hr	EXCELLENT
	Ni+Cu+Ni					
Zinc	Blue Zinc Colour Zinc	Bright Blue Shinny Colour	8-20	24hr	24hr	GOOD
Epoxy	Epoxy	Black / Grey	15-25	48hr	96hr	EXCELLENT
	Ni+Cu+Epoxy					
Tin	Ni+Cu+Sn	Silver	15-20	72hr	72hr	SUPERIOR
Parylene	Parylene	Grey	15-25	96hr	200hr	SUPERIOR
Teflon	Teflon	Grey	10-20	12hr	24hr	SUPERIOR
Phosphorization	/	Grey	1-2	-	-	TEMPORARY PROTECTION
Passivation	/	Grey	1-2	-	-	TEMPORARY PROTECTION

※ PCT Test(120°C, 100%RH, 2.0atm); Salt Spray Test(5%NaCl, 35°C continuous spray).

Item	Parameters	Reference Value
Additional Magnetic Properties	Temp.Coeff.of Br ($\alpha(\text{Br})$)(%/K)	-0.08~-0.12
	Temp.Coeff.of Hcj ($\beta(\text{Hcj})$)(%/K)	-0.42~-0.70
	Curie Temperature (T_c)/K	310~380
	Recoil Permeability (μ_{rec})[-]	1.05
Mechanical and Physical Properties	Density (g/cm^3)	7.6
	Vickers Hardness (Hv)	650
	Electrical Resistivity ($\mu\Omega\text{m}$)	1.4
	Compressive Strength (Mpa)	1050
	Tensile Strength (Mpa)	80
	Bending Strength (Mpa)	290
	Thermal Conductivity ($W/(\text{m}\cdot\text{K})$)	6~8
	Young's Modulus (Gpa)	160
	Coefficient of Thermal Expansive (C_{\perp}) (10-6/K)	-1.5
	Coefficient of Thermal Expansive (C_{\parallel}) (10-6/K)	6.5

※ Technical specifications and parameters are subject to change without notice.

● Application:

- Magnetic Resonance Imaging
- Actuators
- Security Systems
- Magnetic Guitar Pickups
- Electric Generators For Wind Turbines
- Sensors
- Loudspeakers And Headphones
- Specialty Door Catches
- Brushless Motor
- Magnetic Bearings And Couplings
- Magnetic Chuck
- Magnetic Toy
- Electric Motors
- Filter & Strainers
- Magnetic Tools
- Lifting And Compressor Motors
- Health Bandages And Plasters
- Other Magnetic Applications
- Electrical Power Steering
- Magnet Separators

Compression NdFeB Magnet

Bonded Compression magnets are composed of a special form of NdFeB powder with adhesive and using compression molding techniques in simple tools, it can be quickly machined into complex shapes. Since its materials are isotropic, bonded NdFeB magnet can be magnetized in any directions or with multiple poles. Special magnetizing fixtures are required in order to achieve multiple poles magnetization, depending on complexity of design and production.



Advantages of Compression NdFeB Magnet

- Excellent mechanical strength and surface finish.
- Compression molded magnets can be manufactured to very tight tolerance.
- Greater cracking and chipping resistance than other rare earth magnets.
- Superior energy to weight ratio.
- Can be molded into a variety of shapes and sizes.
- Magnetic values up to 10 MGOe.
- Single-time molding and multi-poles orientation.
- Low tooling cost.
- Co-injected assemblies.
- Effective surface treatment to prevent corrosion.
- Widely applied in all kinds of mini-motors, auto motors, air-conditioner motors, automatic controlling devices, sensors, drivers, telecom and instrument industry.
- Stable working temperature: It can be up to 150°C.
- The energy product is 3 times as large as anisotropic ferrite. The intrinsic coercive force is high. During the large-scale production, the magnetic properties are stable and conformity is good.

Magnetic Parameters of Bonded Compression NdFeB Magnet

Properties Grade	Max Energy	Remanence	Coercive Force	Intrinsic	Density	Relative	TempCoeff	Max
	Product			Coercive Force		Recoil	of Remanence	working Temp
	(BH)max	BR	Hcb	Hci	D	permeability	abr	Tw
	KJ/m3(MGOe)	T	KA/m(KOe)	KA/m(KOe)	g/cm3	μr	%/°C	°C
BNP-6	44-56(5.5-7.0)	0.55-0.62	285-370(3.6-4.6)	600-755(7.5-9.5)	5.5-6.1	1.15	-0.13	100
BNP-8L	56-64(7.0-8.0)	0.60-0.64	360-400(4.5-5.0)	715-800(9-10)	5.6-6.1	1.15	-0.13	100
BNP-8	64-72(8.0-9.0)	0.62-0.69	385-445(4.8-5.6)	640-800(8-10)	5.6-6.1	1.15	-0.13	120
BNP-8SR	64-72(8.0-9.0)	0.62-0.66	410-465(5.2-5.8)	800-1120(11-14)	5.6-6.1	1.13	-0.13	150
BNP-8h	64-72(8.0-9.0)	0.61-0.65	410-445(5.2-5.7)	1190-1440(15-18)	5.9-6.2	1.15	-0.07	125
BNP-9	70-76(8.8-9.5)	0.65-0.70	400-440(5.0-5.5)	640-800(8-10)	5.6-6.1	1.22	-0.12	120
BNP-10	76-84(9.5-10.5)	0.68-0.72	420-470(5.3-5.9)	640-800(8-10)	5.6-6.1	1.22	-0.11	120
BNP-11	80-88(10-11)	0.70-0.74	445-480(5.6-6.0)	640-800(8.5-10)	5.6-6.1	1.22	-0.11	120
BNP-11I	78-84(9.8-10.5)	0.70-0.74	400-440(5.0-5.5)	520-640(6.5-8)	5.6-6.1	1.26	-0.11	110
BNP-12L	84-92(10.5-11.5)	0.74-0.80	420-455(5.3-5.7)	520-600(6.5-7.5)	5.6-6.1	1.26	-0.06	110

Injection Bonded NdFeB Magnet

Bonded Injection NdFeB magnet is a kind of new generation composite material made from permanent magnetic powder and plastic. Injection NdFeB powder is blended with a plastic material and injection molded. With High precision size, it can be made of complex shapes and also bonded with other components. The injection molding magnet can be magnetized in any directions with multiple poles.



Advantages of Injection NdFeB Magnet

1. Designing and manufacturing of orientation moulds were carried out.
2. Having high dimensional precision and impact-resistance. Capable of forming products with inlay.
3. The injection molding parts are suitable for forming products with various shapes and thin walls.
4. Multi polar magnetization can be carried out according to customers' requirement.

Application Areas

- Automobile Instrument Cluster
- Dashboard Instrument
- Digital Speedometers
- Sensors
- Roll for Copiers
- DC Micro Motors
- Stepper Motors
- AC Synchronous Motor Magnets
- Electrical Meters
- Coupling Magnets
- Disk Drives
- Clock / Timers
- Reed Relays
- Educational Kits and Scientific Instruments
- Magnet Bearings

Magnetic Characteristics of Bonded Injection NdFeB

Properties	Max Energy	Remanence	Coercive Force	Intrinsic	Density	Relative	TempCoeff	Max							
	Product			Coercive Force					Recoil	of Remanence	working Temp				
	(BH)max			Hcb								Hci	permeability	abr	Tw
	KJ/m3(MGOe)			KA/m(KOe)								KA/m(KOe)	D	μr	%/°C
Grade		T			g/cm3	μr	%/°C	°C							
BNI-3	8-24(1.0-3.0)	0.20-0.40	120-240(1.5-3.0)	480-640(6.0-8.0)	3.9-4.4	1.2	-0.15	100							
BNI-4	28-36(3.5-4.5)	0.40-0.46	250-335(3.1-4.2)	575-735(7.2-9.2)	4.2-4.9	1.2	-0.13	110							
BNI-5	37-44(4.6-5.5)	0.45-0.51	280-360(3.5-4.5)	640-800(8-10)	4.5-5.0	1.2	-0.13	120							
BNI-6	44-52(5.5-6.5)	0.51-0.56	295-375(3.7-4.7)	640-800(8-10)	4.7-5.1	1.13	-0.11	120							
BNI-6II	40-52(5.0-6.5)	0.48-0.56	335-400(4.2-5.0)	1035-1355(13-17)	4.8-5.2	1.13	-0.15	130							
BNI-7	51-59(6.5-7.5)	0.54-0.64	320-400(4.0-5.0)	640-800(8-10)	5.0-5.5	1.13	-0.11	120							
BNI-5SR(PPS)	36-44(4.5-5.5)	0.45-0.50	300-360(3.8-4.5)	875-1115(11-14)	4.9-5.4	1.13	-0.13	150							

Quenched NdFeB Powder



MAGRON magnetic powders are based upon Nd-Fe-B alloy compositions that are quickly solidified from their molten state at high cooling rates. This rapid solidification results in a material that has a precise grain structure. Due to the small grain size, these materials are magnetically isotropic. Unlike the very fine, anisotropic powders that are used to manufacture sintered NdFeB magnets, **MAGRON's** powder is stable against oxidation-forced demagnetization. This makes Newland powders easily ready for making bonded permanent magnets.

Processing Flow:

1. Jet Casting. Firstly, to melt Neodymium-iron-boron ingot, then jet the metal under high pressure onto the surface of a revolving metal wheel that the wheel is kept at cool temperature while the molten metal is cooled. During the process the material solidifies into a

small metal ribbon about 35 μm (micrometers) thickness and 1-3 mm width. By controlling variables such as the flow rate of the metal, the wheels rotating speed, the cooling rate; we can achieve optimum magnetic properties. The gathered ribbon is milled into a platelet and there a heat treatment is carried out to achieve desired magnetic properties.

2. Spinning-cup atomization, much like a centrifuge. Molten metal is ejected into the surface of a rapidly spinning cup and when leaving the rim of the spinning cup, it forms droplets that will form into very small spheres during spinning and solidification. Finally, the powders are collected and heat-treated to achieve desired magnetic properties.

Application:

1. Making isotropic bonded NdFeB magnets, which are manufactured by mixing NdFeB powder with polymer binder and then pressing (compression to form the required shape).
2. The automobile industry: DC brush-type motors, multi-pole stepper and spindle motor applications.
3. Magnetic paints, magnetic printable substrates, magnetic films, medical diagnostics and therapeutics, video tape, copy toners, fingerprinting, sensors, fuel injectors, permanent magnets, nano level fluid sealing, electric toys and magnetic curing products, etc.



The Properties of Magnetic Powder:

Properties Grade	Max Energy Product (BH) _{max} KJ/m ³ (MGOe)	Remanence Br mT(KGs)	Coercive Force H _{cb} KA/m(KOe)	Intrinsic Coercive Force H _{cj} KA/m(KOe)	Density D g/cm ³	Curie Temp T _c °C	Max Working Temp T _w °C
NM-A	80-96 (10.0-12.0)	0.74-0.80 (7.4-8.0)	440-496 (5.5-6.2)	1035-1360 (13.0-17.0)	7.6	310	120
NM-B	64-108 (8.0-13.5)	0.74-0.83 (7.4-8.3)	320-520 (4.0-6.5)	560-800 (7.0-10.0)	7.64	390	120
NM-C	80-96 (10.0-12.0)	0.74-0.81 (7.4-8.1)	440-504 (5.5-6.3)	1035-1360 (13.0-17.0)	7.64	470	150
NM-D	92-108 (11.5-13.5)	0.74-0.83 (7.4-8.3)	440-520 (5.5-6.5)	640-800 (8.0-10.0)	7.64	470	150
NM-ES	56-76 (7.0-9.5)	0.85-1.10 (8.5-11.0)	192-280 (2.4-3.5)	240-400 (3.0-5.0)	7.4	400	100
NM-A(14-12)	14-14.2	8.2-8.4	6.7-6.9	11.5-12.3	7.64	310	120
NM-B(15-9)	14.9-15.2	8.6-8.8	6.5-6.7	9.0-10.0	7.64	390	120

Sintered SmCo Magnets

Samarium Cobalt (SmCo) magnets are made by a sintering process and exist in two forms. The first is Sm₁Co₅ (SmCo 1:5), which has a maximum energy product of between 14 and 24MGOe. The second and more common form is Sm₂Co₁₇ (SmCo 2:17) which has a maximum energy product of between 22 and 32 MGOe. The main Sm₂Co₁₇ alloy is around 35% Samarium (Sm) and 60% Cobalt (Co) with the balance being from varying amounts of Iron (Fe), Copper (Cu), Hafnium (Hf) and Zirconium (Zr). Praseodymium (Pr) may also be used. Sm₁Co₅ is made of only Sm and Co and has excellent corrosion resistance.

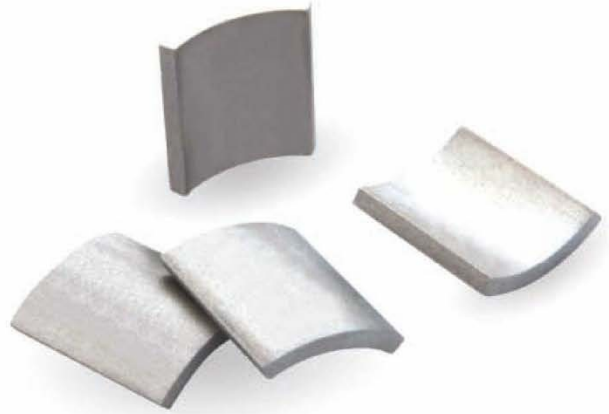

Advantages of SmCo Magnet

1. Superior resistance to high temperature.
2. Excellent resistance to corrosion, no coating is needed for surface protecting.
3. High working temperature.
4. SmCo is suitable for machines with high magnetic requirements and good for strict working environment requirement.

Application :

Electronic Magnetrons
Magnetic Treatment
Servo-Motors
Sensors
Magnetic Transmissions
Magnistors
Pump Couplings
Computer Disc Drives



● Magnetic Characteristics and Physical Properties of SmCo Magnet

Material	Properties	Remanence	Coercive Force	Intrinsic Coercive Force	Max Energy Product	Max Working Temp.
	Grade	Br mT (KGs)	Hcb KA/m (KOe)	Hcj KA/m (KOe)	(BH) _{max} KJ/m ³ (MGOe)	TW °C
Sm1Co5	XG18	820-920(8.2-9.2)	639-756(8.0-9.5)	1194-1751(15-22)	127-159(16-20)	250
	XG20	870-950(8.7-9.5)	639-756(8.0-9.5)	1194-1751(15-22)	143-175(18-22)	250
	XG22	930-1000(9.3-10)	660-772(8.3-9.7)	1194-1751(15-22)	159-191(20-24)	250
	XG24	960-1040(9.6-10.4)	660-780(8.3-9.8)	1194-1751(15-22)	175-207(22-26)	250
Sm2Co17	XGS24	960-1040(9.6-10.4)	660-780(8.3-9.8)	≥ 1194(≥ 15)	175-207(22-26)	350
	XGS24M	960-1040(9.6-10.4)	318-772(4.0-9.7)	398-955(5-12)	175-207(22-26)	350
	XGS24H	960-1040(9.6-10.4)	660-780(8.3-9.8)	≥ 1592(≥ 20)	175-207(22-26)	350
	XGS26	1000-1070(10.0-10.7)	667-820(8.5-10.3)	≥ 1194(≥ 15)	191-223(25-28)	350
	XGS26M	1000-1070(10.0-10.7)	318-796(4.0-10.0)	398-955(5-12)	191-223(25-28)	350
	XGS26H	1000-1070(10.0-10.7)	667-820(8.5-10.3)	≥ 1592(≥ 20)	191-223(25-28)	350
	XGS28	1040-1100(10.4-11)	677-820(8.5-10.3)	≥ 1194(≥ 15)	207-239(26-30)	350
	XGS28M	1040-1100(10.4-11)	318-796(4.0-10.0)	398-955(5-12)	207-239(26-30)	350
	XGS28H	1040-1100(10.4-11)	677-820(8.5-10.3)	≥ 1592(≥ 20)	207-239(26-30)	350
	XGS30	1070-1120(10.7-11.2)	677-820(8.5-10.3)	≥ 1194(≥ 15)	223-247(28-31)	350
	XGS30M	1070-1120(10.7-11.2)	318-796(4.0-10.0)	398-955(5-12)	223-247(28-31)	350
	XGS32	1090-1150(10.9-11.5)	677-820(8.5-10.3)	≥ 955(≥ 12)	238-262(29-32)	350
	XGS32M	1090-1150(10.9-11.5)	318-796(4.0-10.0)	398-955(5-12)	238-262(29-32)	350
	Low Temp. Coeff Sm2Co17	XSG22LT	930-1000(9.3-10.0)	677-756(8.5-9.5)	≥ 1194(≥ 15)	159-191(20-24)
XSG24LT		960-1040(9.6-10.4)	677-756(8.5-9.5)	≥ 1194(≥ 15)	175-207(22-26)	350
XSG26LT		1000-1070(10.0-10.7)	677-812(8.5-10.2)	≥ 1433(≥ 18)	191-223(25-28)	350

NOTE: Due to the fast development of technology, the performance index may be adjusted accordingly. Customers should follow the latest version. In addition to above grades, our company can also produce special performance.

AlNiCo Magnet

AlNiCo is composed primarily of Aluminum, Nickel, Cobalt, and also Copper and Titanium. They are manufactured through either casting or sintering process. Cast AlNiCo may be manufactured in complex shapes, such as horseshoes, not possible with other magnet materials. Sintered AlNiCo offer slightly lower magnetic properties but better mechanical characteristics than Cast AlNiCo.

For isotropic AlNiCo magnet, it can be efficiently magnetized in any direction, and for anisotropic AlNiCo magnet, it generally has greater magnetic capacity in a preferred orientation than isotropic types.

AlNiCo is hard and brittle. Machining or drilling cannot therefore be accomplished by ordinary methods. Holes are usually cored in at the foundry, and magnets are cast close to final size and then finish machined to closer tolerances.



*Customized designs are available.

*Max working temperature can be as high as 550°C.

*Disadvantage: Br and BH (max) are not as high as rare earth magnet.

*Advantage: High energies and relatively low coercivity; High magnetic flux density; low mould charge; stable temperature properties; easy to shape.

Application:

- Electronic Ignition Systems
- Watt Hour Meters
- Medical Instruments
- Guitar Pickups
- Industrial Motors
- Hand Tools
- Vending Machines
- Automatic Control Appliance

Typical Magnetic Properties for Cast AlNiCo Magnet

Properties Grade	US Standard MMPA Equivalent	Max Energy Product (BH) _{max} KJ/m ³ (MGOe)	Remanence Br mT (KGs)	Coercivity Force Hc KA/m(Oe)	Density D g/cm ³	Temp coefficient		Curie Temp T _c °C	Max Working Temp T _c °C	Remark
						αBr %/°C	βHci %/°C			
LN9	AlNiCo3	9.0(1.13)	680(6.8)	30(380)	6.9	-0.03	-0.02	810	450	Isotropic
LN10	AlNiCo3	10.0(1.20)	600(6.0)	40(500)	6.9	-0.03	-0.02	810	450	
LNG12	AlNiCo2	12.4(1.55)	720(7.2)	45(500)	7.0	-0.03	+0.02	810	450	
LNG13	AlNiCo2	12.8(1.60)	700(7.0)	48(600)	7.0	-0.03	+0.02	810	450	
LNGT18	AlNiCo8	18.0(2.2)	580(5.8)	100(1250)	7.3	-0.025	+0.02	860	550	
LNG37	AlNiCo5	37.0(1.65)	1200(12.0)	48(600)	7.3	-0.02	+0.02	850	525	
LNG40	AlNiCo5	40.0(5.0)	1250(12.5)	48(600)	7.3	-0.02	+0.02	850	525	
LNG44	AlNiCo5	44.0(5.5)	1250(12.5)	52(650)	7.3	-0.02	+0.02	850	525	
LNG52	AlNiCo5DG	52.0(6.5)	1300(13.0)	56(700)	7.3	-0.02	+0.02	850	525	
LNG60	AlNiCo5-7	60.0(7.5)	1350(13.5)	59(740)	7.3	-0.02	+0.02	850	525	
LNGT28	AlNiCo6	28.0(3.5)	1080(10.8)	58(720)	7.3	-0.02	+0.03	850	525	
LNGT36J	AlNiCo8H	36.0(4.5)	700(7.0)	140(1750)	7.3	-0.025	+0.02	860	550	
LNGT32	AlNiCo8	32.0(4.0)	800(8.0)	100(1250)	7.3	-0.025	+0.02	860	550	
LNGT40	AlNiCo8	40.0(5.0)	800(8.0)	110(1380)	7.3	-0.025	+0.02	860	550	
LNGT60	AlNiCo9	60.0(7.5)	900(9.0)	110(1380)	7.3	-0.025	+0.02	860	550	
LNGT72	AlNiCo9	72.0(9.0)	1050(10.5)	112(1400)	7.3	-0.025	+0.02	860	550	

Typical Magnetic Properties for Sintered AlNiCo Magnet

Properties Grade	Max Energy Product BH(max) KJ/m ³	Remanence Br mT	Coercive Force Hcb KA/m	Intrinsic coercive Force Hcj KA/m	Density D g/cm ³	Temp coefficient α(Br) %/K	Curie Temp T _c °C	Remarks
SAlNiCo4/1	3.2-4.8	870-890	9-11	10-12	6.8	-0.02	750	Isotropy
SAlNiCo8/5	8.5-9.5	530-620	45-50	47-52	6.8	-0.02	750	
SAlNiCo10/5	9.5-11	630-700	48-56	50-58	6.8	-0.02	780	
SAlNiCo12/5	11-13	700-750	50-56	53-58	7.0	-0.02	800	
SAlNiCo14/5	13-15	730-800	47-50	50-53	7.1	-0.02	790	
SAlNiCo14/6	14-16	620-810	56-64	58-66	7.1	-0.02	790	
SAlNiCo14/8	14-16	550-610	75-88	80-92	7.1	-0.01	850	
SAlNiCo18/10	16-19	570-620	92-100	99-107	7.2	-0.01	860	
SAlNiCo35/5	35-39	1100-1200	48-52	50-54	7.20	-0.02	850	
SAlNiCo29/6	29-33	970-1090	58-64	60-66	7.20	-0.02	860	
SAlNiCo32/10	33-38	770-870	90-104	94-109	7.20	-0.01	860	
SAlNiCo33/11	33-38	700-800	107-115	111-119	7.20	-0.01	860	
SAlNiCo39/12	39-43	830-900	115-123	119-127	7.25	-0.01	860	
SAlNiCo44/12	44-48	900-950	119-127	124-132	7.25	-0.01	860	
SAlNiCo37/15	37-41	700-800	143-151	150-158	7.10	-0.1	870	

Ferrite Magnet

○ Sintered Ferrite

Sintered Ferrite Magnet is manufactured from oxide material by powder metallurgical process. Its advantages include: low cost, excellent corrosion resistance, resistance to be demagnetized etc. The normal working temperature of Ferrite Magnet is between -40°C and $+250^{\circ}\text{C}$. It can be magnetized before or after assembling. Generally, sintered Ferrite Magnet can be machined to regular shapes like segments, blocks, rings and discs etc. The normal grades for sintered Ferrite Magnets are Y10T, Y25, Y30, Y30BH, Y35 etc.

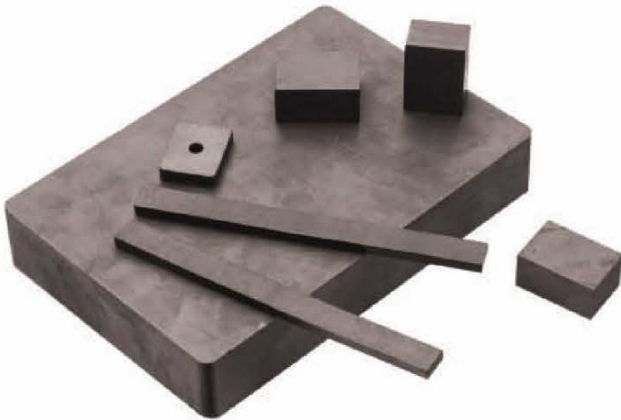

○ Injection Ferrite

It is made of bonded ferrite magnet powder, plastics (PVC, Nylon, PP, etc) and other materials. During the injecting process, the combination can be made into flexible magnets with precise sizes and complicated shapes, which can be assembled with metal and plastic parts.

○ Typical Applications:

DC Permanent Motor
Duplicator Roller and so on



○ Typical Applications:

Electric Motor
Loudspeaker
Magnetic Knife Holder /Rack
General Holding Devices and so on



Typical Magnetic Properties for Ferrite Magnet

Grade	Br		Hc		BHc		J(BH)max	
	mT	KG	KA/m	K0e	KA/m	K0e	Kj/M3	MGOe
Y8T	200-235	2.00-2.35	125-160	1.57-2.01	210-280	2.64-3.51	6.50-9.50	0.8-1.2
Y20	320-380	3.2-3.8	135-190	1.70-2.38	140-195	1.76-2.45	18.0-22.0	2.-2.8
Y22H	310-360	3.10-3.60	220-250	2.77-3.14	280-320	3.51-4.02	20.0-24.0	2.5-3.0
Y23	320-370	3.2-3.7	170-190	2.14-2.38	190-230	2.39-2.89	20.0-25.5	2.5-3.2
Y25	360-400	3.60-4.00	135-170	1.70-2.14	140-200	1.76-2.51	22.5-28.0	2.8-3.5
Y26H-1	360-390	3.60-3.90	220-250	2.51-3.14	225-255	2.83-3.20	23.0-28.0	2.9-3.5
Y26H-2	360-380	3.60-3.80	263-288	3.30-3.62	318-350	3.99-4.40	24.0-28.0	3.0-3.5
Y27H	350-380	3.50-3.80	225-240	2.83-3.01	235-260	2.95-3.27	25.0-29.0	3.1-3.6
Y28	370-400	3.70-4.00	175-210	2.20-3.64	180-220	2.26-2.76	26.0-30.0	3.3-3.8
Y28H-1	380-400	3.80-4.00	240-260	3.01-3.27	250-280	3.14-3.52	27.0-30.0	3.3-3.8
Y28H-2	360-380	3.60-3.80	271-295	3.40-3.70	382-405	4.80-5.08	26.0-32.5	3.4-3.8
Y30BH	380-390	3.8-3.9	223-235	2.80-2.95	231-245	2.90-3.08	27.0-30.0	3.4-3.7
Y30H-1	380-400	3.80-4.00	230-275	2.89-3.46	235-290	2.95-3.64	27.0-32.5	3.3-3.8
Y30H-2	395-415	3.95-4.15	275-300	3.45-3.77	310-335	3.89-4.20	27.0-32.0	3.4-4.1
Y10T	380-400	3.8-4.0	230-275	2.89-3.46	235-290	2.95-3.65	27.0-32.0	3.4-4.0
Y20-2	395-415	3.95-4.15	275-300	3.46-3.77	310-335	3.90-4.21	28.5-32.5	3.5-4.0
Y32	400-420	4.00-4.20	160-190	2.01-2.37	165-195	2.07-2.45	30.0-33.5	3.4-4.0
Y32H-1	400-420	4.00-4.20	190-230	2.39-2.89	230-250	2.89-3.14	31.5-35.0	3.9-4.4
Y32H-2	400-440	4.00-4.40	224-240	2.80-3.01	230-250	2.89-3.14	31.0-34.0	3.9-4.3
Y33	410-430	4.10-4.30	220-250	2.76-3.14	225-255	2.83-3.20	31.5-35.0	3.9-4.4
Y33H	410-430	4.10-4.30	250-270	3.14-3.39	250-275	3.14-3.45	31.5-35.0	3.9-4.4
Y34	420-440	4.20-4.40	200-230	2.51-2.89	205-235	2.57-2.95	32.5-36.0	4.1-4.4
Y35	430-450	4.30-4.50	215-239	2.70-3.00	217-241	2.73-3.03	33.1-38.2	4.1-4.8
Y36	430-450	4.30-4.50	247-271	3.10-3.40	250-274	3.14-3.44	35.1-38.3	4.4-4.8
Y38	440-460	4.40-4.60	285-305	3.58-3.83	294-310	3.69-3.89	36.6-40.6	4.6-5.1
Y40	440-460	4.40-4.60	330-354	4.15-4.45	340-360	4.27-4.52	37.6-41.8	4.7-5.2

Typical Magnetic Properties for Ferrite Magnet

USA Standard								
Material	Br		Hc		BHc		(BH)max	
	mT	KG	KA/m	K0e	KA/m	K0e	Kj/M3	MGOe
C1	230	2.30	148	1.86	258	3.50	8.36	1.05
C5	380	3.80	191	2.40	199	2.50	27.0	3.40
C7	340	3.40	258	3.23	318	4.00	21.9	2.75
C8(C8A)	385	3.85	235	2.95	242	3.05	27.8	3.50
C8B	410	4.10	230	2.90	235	2.95	28.7	3.60
C8C	430	4.30	199	2.50	203	2.55	34.2	4.30
C9	380	3.80	280	3.51	320	4.01	26.4	3.32
C10	400	4.00	288	3.62	280	3.51	30.4	3.82
C11	430	4.30	200	2.51	204	2.56	34.4	4.32
C12	400	4.00	290	3.64	318	3.99	32.0	4.02

Japan Standard(TDK)								
FB1A	220+/-15	2.2+/-0.15	159+/-15.9	2.0+/-0.2	259+/-19.9	3.25+/-0.25	8.9+/-1.6	1.12+/-0.2
FB3G	375+/-15	3.75+/-0.15	255+/-15.9	3.2+/-0.2	271+/-19.9	3.40+/-0.25	25.9+/-2.4	3.25+/-0.3
FB3N	395+/-10	3.95+/-0.1	235+/-11.9	2.95+/-0.15	239+/-15.9	3.00+/-0.20	28.7+/-2.4	3.60+/-0.3
FB4D	410+/-10	4.1+/-0.1	235+/-11.9	2.95+/-0.15	238+/-11.9	3.00+/-0.15	31.4+/-1.6	3.94+/-0.2
FB4A	410+/-10	4.1+/-0.1	175+/-11.9	2.2+/-0.15	323+/-11.9	4.06+/-0.15	31.8+/-1.6	3.99+/-0.2
FB5H	405+/-10	4.05+/-0.1	298+/-11.9	3.74+/-0.15	322+/-11.9	4.05+/-0.15	31.1+/-1.6	3.91+/-0.2
FB5B	420+/-10	4.2+/-0.1	263+/-11.9	3.3+/-0.15	323+/-11.9	4.06+/-0.15	33.4+/-1.6	4.20+/-0.2
FB5N	440+/-10	4.4+/-0.1	227+/-11.9	2.85+/-0.15	229+/-11.9	2.87+/-0.15	36.7+/-1.6	4.61+/-0.2
FB6E	380+/-10	3.8+/-0.1	291+/-11.9	3.65+/-0.15	394+/-11.9	4.95+/-0.15	27.5+/-1.6	3.45+/-0.2
FB6H	400+/-10	4.0+/-0.1	303+/-11.9	3.81+/-0.15	358+/-11.9	4.50+/-0.15	30.3+/-1.6	3.81+/-0.2
FB6B	420+/-10	4.2+/-0.1	303+/-11.9	3.81+/-0.15	318+/-11.9	3.99+/-0.15	33.4+/-1.6	4.20+/-0.2
FB6N	440+/-10	4.4+/-0.1	259+/-11.9	3.25+/-0.15	263+/-11.9	3.30+/-0.15	36.7+/-1.6	4.60+/-0.2
FB9H	430+/-10	4.3+/-0.1	331+/-11.9	4.16+/-0.15	398+/-11.9	5.00+/-0.15	35.0+/-1.6	4.40+/-0.2
FB9B	450+/-10	4.5+/-0.1	342+/-11.9	4.30+/-0.15	358+/-11.9	4.50+/-0.15	38.2+/-1.6	4.80+/-0.2
FB9N	460+/-10	4.6+/-0.1	279+/-11.9	3.5+/-0.15	286+/-11.9	3.60+/-0.15	40.4+/-1.6	5.07+/-0.2

● Typical Magnetic Properties for Ferrite Magnet

Europe Standard								
Grade	Allowed Value (min/typical)							
	Br		Hcb(BHC)		Hcj(IHC)		(BH)max	
	mT	KG	KA/m	K0e	KA/m	K0e	Kj/M3	MGOe
HF8-22	220-220	2.00-2.20	125-140	1.57-1.76	220-230	2.76-2.89	6.5-6.8	0.8-1.1
HF20-19	320-333	3.20-3.33	170-190	2.14-2.39	190-200	2.39-2.51	20.0-21.0	2.5-2.7
HF20-28	310-325	3.10-3.25	220-230	2.76-2.89	280-290	3.52-3.64	20.0-21.0	2.5-2.7
HF22-30	350-365	3.50-3.65	255-265	3.20-3.33	290-300	3.64-3.77	22.0-23.5	2.8-3.0
HF24-16	350-365	3.50-3.65	155-175	1.95-2.20	160-180	2.01-2.26	24.0-25.5	3.0-3.2
HF24-23	350-365	3.50-3.65	220-230	2.76-2.89	230-240	2.89-3.01	24.0-25.5	3.0-3.2
HF24-35	360-370	3.60-3.70	260-270	3.27-3.39	350-360	4.40-4.52	24.0-25.5	3.0-3.2
HF26-16	370-380	3.70-3.80	155-175	1.95-2.20	160-180	2.01-2.26	26.0-27.0	3.2-3.4
HF26-18	370-380	3.70-3.80	175-190	2.20-2.39	180-190	2.26-2.39	26.0-27.0	3.3-3.4
HF26-24	370-380	3.70-3.80	230-240	2.89-3.01	240-250	3.01-3.14	26.0-27.0	3.3-3.4
HF26-26	370-380	3.70-3.80	230-240	2.89-3.01	260-270	3.27-3.39	26.0-27.0	3.3-3.4
HF26-30	385-395	3.85-3.95	260-270	3.27-3.39	300-310	3.77-3.89	26.0-27.0	3.3-3.4
HF28-26	385-395	3.85-3.95	250-265	3.14-3.33	260-275	3.27-3.45	28.0-30.0	3.5-3.8
HF28-28	385-395	3.85-3.95	260-270	3.27-3.39	280-290	3.50-3.60	28.0-30.0	3.5-3.8
HF30-26	395-405	3.95-4.05	250-260	3.14-3.33	260-270	3.27-3.39	30.0-31.5	3.8-3.9
HF32-17	410-420	4.10-4.20	160-180	2.01-2.26	165-175	2.07-2.20	32.0-33.0	4.0-4.1
HF32-22	410-420	4.10-4.20	215-225	2.70-2.83	220-230	2.76-2.89	32.0-33.0	4.0-4.1
HF32-25	410-420	4.10-4.20	240-250	3.01-3.14	250-260	3.14-3.27	32.0-33.0	4.0-4.1

Spheres



Axially Magnetized

Magnetized through the diameter (Like the Earth). Strongest points are on opposite ends.

Cylinder | Disc | Rod



Axially Magnetized

Magnetized through the diameter (Like the Earth). Strongest points are on opposite ends.



Diametrically Magnetized.

Magnetized through the diameter. Strongest points are on the curved surface.

Ring



Axially Magnetized

Magnetized through the diameter (Like the Earth). Strongest points are on opposite ends.



Diametrically Magnetized.

Magnetized through the diameter. Strongest points are on the curved surface.

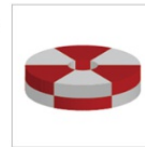

Multi Axially Magnetized

Magnetized by multi magnetizing coil, can be 4, 6, 8 and more poles on the one face



Radially Magnetized

Magnetized on the diameter of the magnets. All north, all south, or alternating polarities.

Cubes | Rectangles



Through The Thickness.

Magnetized through the thickness. Strongest points on the ends of the thickness. Thickness is usually the smallest dimension of a rectangle.



Through the Width.

Magnetized through the width. Strongest points on the ends of the width. Width is usually the 2nd largest dimension of a rectangle.



Through the Length.

Magnetized through the length. 2 Strongest points on the ends of the Length. Length is usually the largest dimension of a rectangle.

Arc | Segment



Diametrically Magnetized Arc.

Magnetized from the Inside Radius (r) through the Outside Radius (R). Strongest points are on the curved surfaces.



Chord Magnetized Arc.

Magnetized Across the Arc. Strongest points are on the flat angled faces



Axially Magnetized Arc.

Magnetized through the thickness. Strongest points are on the flat faces.

Cup Magnets

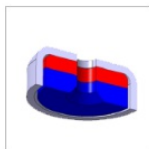

Axially Magnetized.

A Cup or Pot is a regular magnet inside of a stainless steel shell. This shell absorbs the magnetic field on one side and forces it toward the opposite direction, creating a double pull at one end of the magnet. The Stainless steel shell doubles as a very tough layer of protection form harsh environments.

Magnetic Coupling

MAGRON Magnetics is professional in producing and assembling of permanent magnet coupling with high quality components. Our CNC machines produce the highest possible grade components for our magnet coupling.



Magnetic couplings consist of an outer and an inner drive. The two drives do not touch each other. The magnetic couplings work via the non-contact transfer of power. Attractive and repulsive magnetic forces are harnessed to perform work in either a linear or rotary fashion. They are used in the pump industry, pharmaceutical industry, chemical industry, biotech industry, military industry and food industry.

The magnetic materials used for magnetic couplings are Neodymium Iron Boron, Samarium Cobalt and various Alnico and Ceramic.

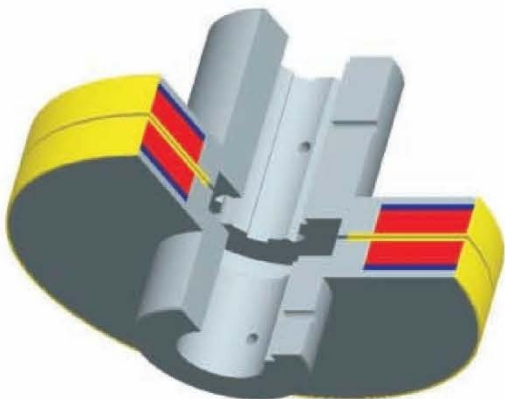

Magnetic System

MAGRON Magnetics is producing and assembling magnetic sensors for customized designs. Most our magnetic sensors are exported to all over the world. Our customers are satisfied with our quality. Our small magnets are required in magnetic sensor products. They are with accurate tolerance and consistent magnetism property.

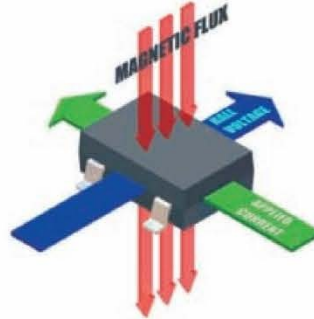
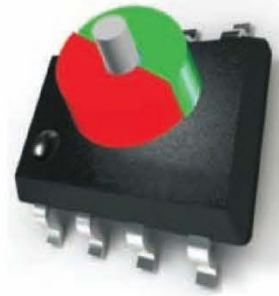

Magnetic sensor is a converter that measures a physical quantity and converts it into a signal which can be read by an observer or by an (today mostly electronic) instrument. Magnetic sensors are used in everyday objects such as touch-sensitive elevator buttons (tactile sensor) and lamps which dim or brighten by touching the base. There are also innumerable applications for sensors of which most people are never aware. The most widely used magnetic sensors measure temperature, pressure or flow. Applications include manufacturing and machinery, airplanes and aerospace, cars, medicine and robotics.

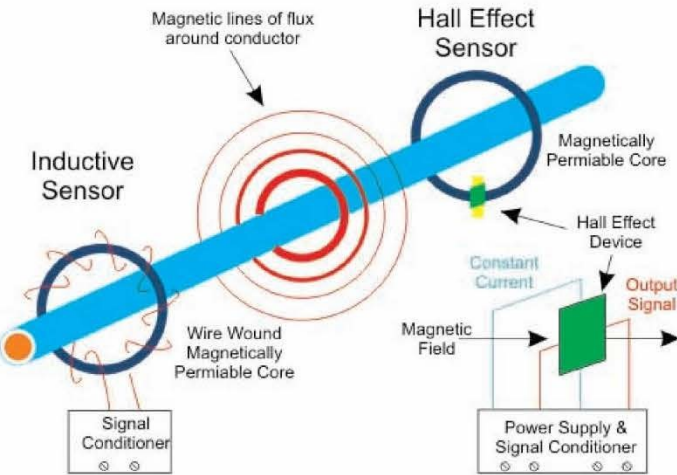

Magnetic sensor is a device, which responds to an input quantity by generating a functionally related output usually in the form of an electrical or optical signal. Magnetic sensor's sensitivity indicates how much the sensor's output changes when the measured quantity changes. Magnetic sensor provides the sensitivity for enhanced accuracy and performance. Permanent Magnets offer high field homogeneity with a small size.



Magnetic Motor

● Rotor

In an electric motor, the moving part is the rotor which turns the shaft to deliver the mechanical power. The rotor usually has conductors laid into it which carry currents that interact with the magnetic field of the stator to generate the forces that turn the shaft. However, some rotors carry permanent magnets, and the stator holds the conductors.



● Stator

The stationary part is the stator, usually has either windings or permanent magnets. The force between the two magnetic fields tends to rotate the motor shaft. The commutator switches power to the coils as the rotor turns, keeping the magnetic poles of the rotor from constant aligning with the magnetic poles of the stator field, so that the rotor never stops (like a compass needle does), as long as power is applied.

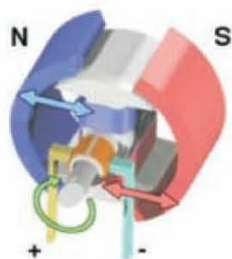

● Application:

1. Small in size, high control precision: Floppy disk driver, Hard disk driver, Memory drum electromotor, Tape servo system.
2. Good speedability, High positioning accuracy, Big starting torque, Strong overload capacity: CNC machine systems, the robot control system.
3. Transportation: Electrical Bicycle, Electric Vehicle, Hybrid Vehicle, City Tram.
4. High unit volume power density: Such as Refrigerator, Air conditioner and other Household electrical appliances.



PM Brushless DC Motor



AC Electric Motor

Permanent-magnet synchronous motor (PMSM) or permanent-magnet motor (PMM) uses permanent magnets rather than windings in the rotor.

Rotor assembling manner:



Linear Motor:

A linear motor is an electric motor that has its stator and rotor "unrolled" instead of producing a torque (rotation). It produces a linear force along its length. Free-body diagram of a U-channel synchronous linear motor as below:

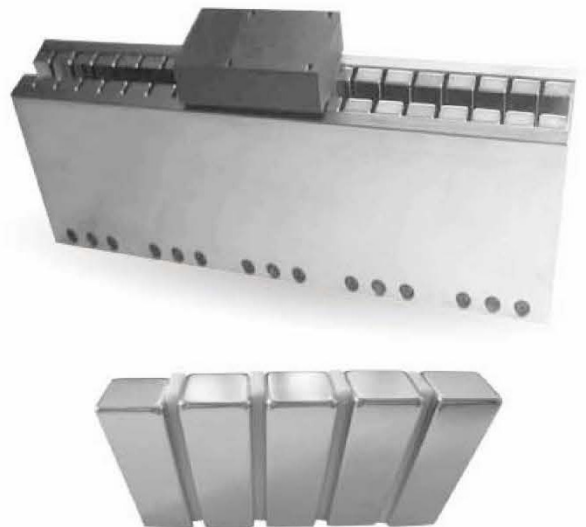
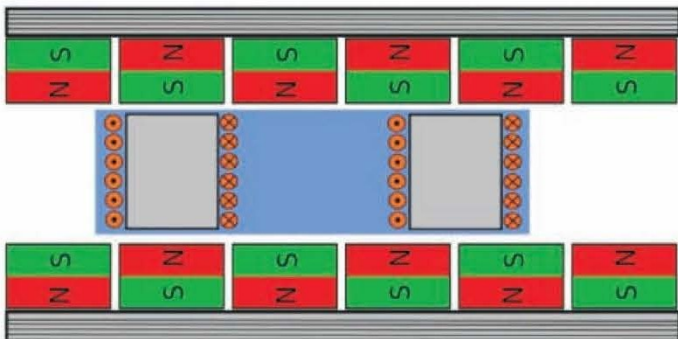

● **Bigger Sizes are Available**



● **Bigger Sizes are Available**



● **Customized Design Magnet Filter and Separator**



● **Round Grate Magnets (Type B)**

P/N	Grate Diameter	Thickness
NL-RGM6"	6"	According to your designs
NL-RGM7"	7"	According to your designs
NL-RGM8"	8"	According to your designs
NL-RGM9"	9"	According to your designs
NL-RGM10"	10"	According to your designs
NL-RGM11"	11"	According to your designs
NL-RGM12"	12"	According to your designs

Magnetic Speaker Assembly

● Magnetic Assembly for Audio Speaker, the Soul of Sound System Performance

A circular magnetic assembly could be often found in sound system, speaker driver. To be specifically, products such as Car Horn, Car Audio, Loudspeaker or Earphone, they will be all assembled with magnets.



● Precise Accuracy

MAGRONMagnetics has great experience in magnet assembly manufacturing. Magnet assembly has been one of the most popular goods that demanded by clients all over the world. It is favored due to extremely high accuracy, 0.03-0.05mm production tolerance after plating.



To justify a great sound system performance, it is assessed by Total Harmonic Distortion, or THD. A magnet assembly, with delicate accuracy could minimize the THD. In a word, better sound quality.



Variable Magnetic Flux

Apart from accuracy, Magnetic Flux is also critical to the speaker. Higher magnetic flux produces higher acoustic sensitivity, it is measured by DB. However, high acoustic sensitivity does not always bring the best sound effect. To be definitive, it only contributes to the sound positively when the sensitivity matches music which is the reason, that **MAGRON** Magnet offers so many different solutions regarding magnet assembly.



Tweeter Audio

- A tweeter loudspeaker is used for high-frequency sounds, typically those sounds used to repel animals or to produce high-frequency noises in songs, movies and other audio. There are many tweeter speakers, such as the cone speaker, which has a small and fast cone and looks like a woofer.
- The faster the crystal and the diaphragm oscillate, the higher the pitch of the sound. A piezoelectric tweeter is not found in every audio setup. Some basic sound systems simply rely on a medium sized speaker to create vibrations on a general range of frequencies.

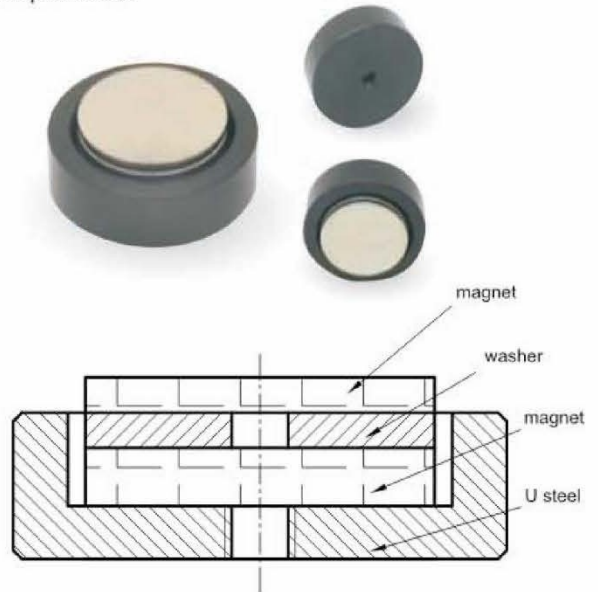

Range of Working Temperature

Magnet worked in speaker has to match the working temperature. They are used indoor & outdoor. The environments need to be considered. For instance, Grade N52 has particular strong magnetic flux, but its working temperature should be controlled within 60 degrees. Exceeding temperature would cause de-magnetization. Therefore, clients who have special needs have to choose higher grade of magnet. The maximum temperature of NdFeB material is around 200 degrees, in Celsius.



Office & Home Magnet

○ Magnetic Door Catcher

39.5x13.5x10mm / 39.6x26.05x9.4mm / 65.61x21x9.4mm

Black&White plastic housing.

Block ferrite / rubber / neodymium magnet

Magnet has approximately 30N-100N pull.

53x25.4x18.4mm

Metal plastic housing.

Block rubber magnet

Magnet has approximately ? pull.

D16.9x21.4mm

Black&White plastic housing.

Block ferrite magnet

Magnet has approximately 25N pull.



○ Office Magnet

Eliminates the need to tape or pin.

Heavy-duty magnets fasten paper and other objects to most file cabinets or metal presentation boards.

3 times stronger than standard magnets!

Includes a reusable plastic tub for simple storage.



○ Magnetic Clip

D65x7mm

Features: Spring loaded hinge. Magnet on back side.

Application: Clip in note and stick to fridge!

Perfect for reminders, memos and a photos.

Alligator style promotional memo clip



○ Magnetic Push Pin

Size: D19x25mm

Pull force: no problem to hold up to 16 pieces of paper.

Color: random colors as customized: white, blue, yellow, black, purple, rose ect, or supply with assorted colors;

Application: used for refrigerator, office, educational, restaurant, ect;

Material: rare earth neodymium magnet, very strong



● Cow Magnet

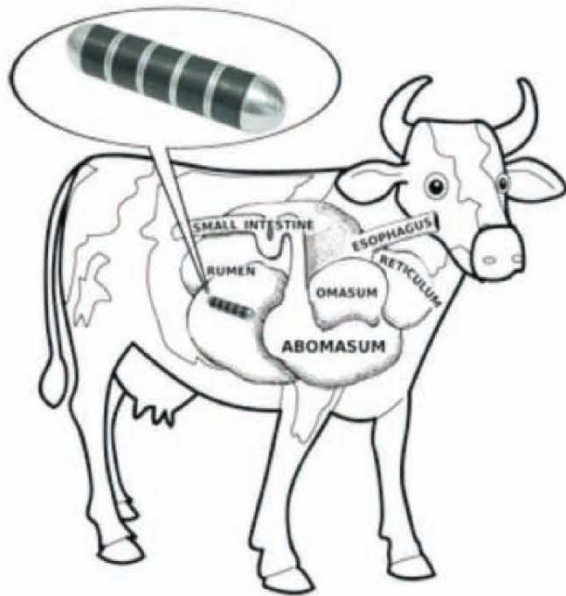

Type three:

Size: 1/2" dia. x 3" length

Material: NdFeB magnet and metal parts

N.W.: 61.5g



Type two:

Size: 1/2" dia. x 3" length

Material: AlNiCo magnet

N.W.: 66.5g



Type four:

Size: 1/2" x 3/4" x 2-3/4"

Material: Ferrite magnet

N.W.: 65.5g

Cow magnets are popular with dairy farmers and veterinarians to help prevent Hardware Disease in their cattle. Hardware Disease is caused when cows swallow a relatively heavy and sharp object such as nails, wire fencing, etc., which eventually finds its way to the rumen and the reticulum. The contractions from the reticulum can potentially become life threatening for cow. Cow magnets help prevent this disease by attracting stray metal from the folds and crevices of the rumen and reticulum.



Type one:

Size: 3/4" dia. x 3-3/8" length

Material: Ferrite magnet and metal parts

N.W.: 120g

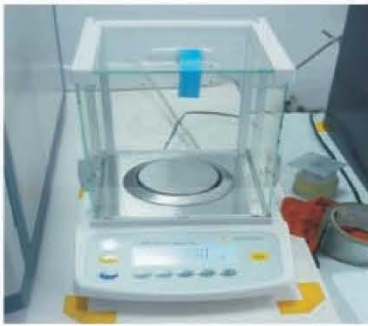

● Analytical Scales



● Carbon-Sulfur Analyzer



● Hysteresigraph



● Projector One



● Projector Two



● Laser Particle Size Analyzer



● X-ray thickness tester



● Oxygen Content Analyzer



● Magnetic Tester



● Magnetic Variation Tester



● Salt Spray Tester



● Inductive Coupling Plasma Atomic Emission Spectrometer

SAFETY GUIDELINES



1. All data of (BH) max, Br, Hcj, Hcb presented in the product performance catalog were measured according to the standard of GB/T3217-92. The parameters will vary if the testing conditions are different.
2. If the magnet is hit or dropped, one should always confirm the plating or coating is not damaged. Don't use magnets whose surface plating or coating has been damaged.
3. In general, the magnetization of a magnet will be reduced if it is heated. Its magnetic properties will be completely lost at the Curie point. Accordingly, the magnetic properties of any given magnet will differ substantially from its specifications based on the operating temperatures. In designing magnetic circuits, special attention must be paid to avoid overheating which deteriorates the magnetic properties.
4. The magnetic fields can change or damage the calibration of sensitive electronic devices and measuring instruments. Pls note that magnetized magnets must be kept at a safe distance from floppy disks, magnetic cards, magnetic tapes, prepaid cards or other devices.
5. Avoid using and storing magnets under the following environments. Violation may cause corrosion of rare earth magnets as well as deterioration of the properties and the strength of the magnet:
 - ① Corrosive gas (Cl₂, NH₃, SO_x, NO_x)
 - ② Environments of high conductivity (e.g., in water containing electrolytes, etc.)
 - ③ Acidic, alkaline, and organic solvents, etc.
 - ④ Hydrogen atmosphere.
 - ⑤ High temperature and humidity
6. Due to weak resistance to impact, rare earth magnets can be easily broken and chipped. Care must be taken to use rare earth magnets.
7. Unexpected personal injury may occur during transport or assemble magnetized magnets. Fingers can be injured between two strongly attractive magnets.

Please contact **MAGRON** Magnet when you choose any one of our products.